

RO-M Fusion

REVOLUTIONIZE YOUR
END-OF-LINE [PACKAGING]
PERFORMANCE

MOSCA

EN

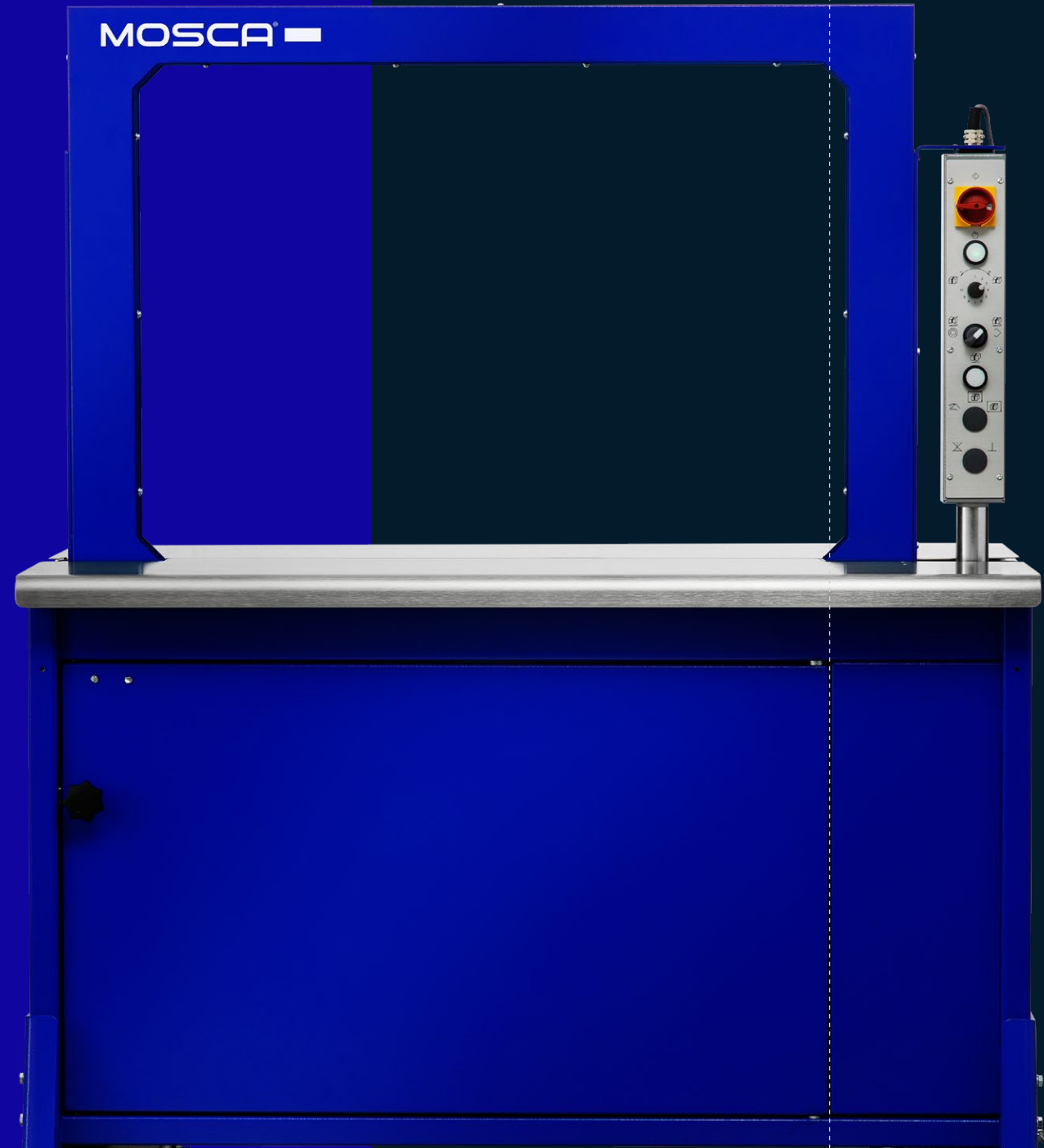

NONSTOP RESPONSIBLE
NONSTOP RELIABLE
NONSTOP INTELLIGENT
NONSTOP PROGRESSIVE

Automatic Strapping Machine 

Newspapers & Print Media, Mail Order & Logistics,
Food & Beverage, Corrugated Cardboard & Paper 

Heat-weld Sealing Unit | Standard-3 

Energy-efficient electrical drives 

For PP straps 

Entry-level machine 

NONSTOP PERFORMANCE

RO-M Fusion

AUTOMATIC STRAPPING MACHINE FOR UNIVERSAL APPLICATIONS

The RO-M Fusion is a durable entry-level machine that automatically and reliably straps packages from all industry sectors. It is adaptable to a wide variety of products with simple handling. Standard features include a turnable operation panel and additional foot pedal for convenient operation from both sides.

TECHNICAL DATA

Performance:
Up to 55 cycles per minute at a frame size of
600x500 mm

Frame Sizes: (WxH)
600 x 500 mm
800 x 600 mm
1,250 x 600 mm

Working Height:
800 - 905 mm

Straps:
PP straps: 5 x 0.47 mm
8 x 0.45 mm
12 x 0.55 mm

Strap Coil Dispenser:
Core diameter: 200 mm
Core width: 190 mm

Electricity:
Voltage: 100 - 240 V, 50 / 60 Hz, 1L+N+PE
(others on request)
Power consumption: approx. 0.2 kW

Weight: (without options)
180 - 240 kg

STANDARD FEATURES

Heat-weld sealing unit in standard-3 version

Wear-free DC drive, brushless motor technology

Strap end detection with ejection of remaining strap

Easy strap coil change and threading system

Soft strapping selectable for sensitive packages

Low-wear, controlled strap path system

Adjustable strap tension via potentiometer

Energy-saving drives

Electronic control

Hinged front table top

Manual strapping release via fixed foot pedal

2 fixed castors not lockable, 2 swivel castors lookable

Table top length 600 mm or alternatively 700 mm
or 800 mm

CE marking inclusive conformity declaration

OPTIONS

E-package:
Automatic strap release via light sensor with selection of single or permanent strapping and strap tension control via light barrier. Three different strap tensions are explicitly storable by the customer

DIMENSIONS / WORKING WIDTH MACHINE (in mm)

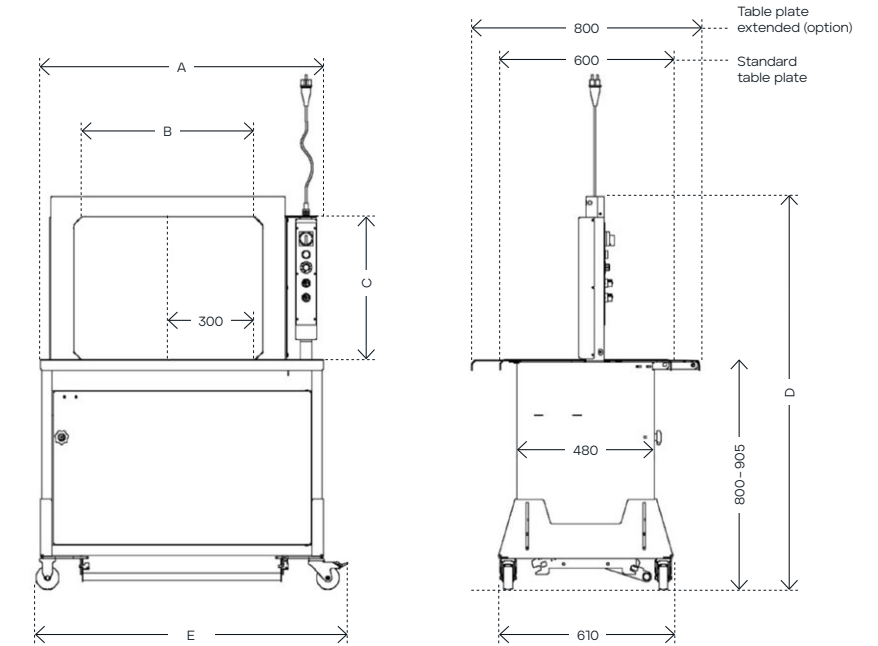

	A	B	C	D	E
600x500	990	600	500	1,370-1,475	1,090
800x600	1,190	800	600	1,470-1,575	1,290
1,250x600	1,640	1,250	600	1,470-1,575	1,740



HOLISTIC SUPPORT WITH THE MOSCA SYSTEM

Suitable consumables available directly from Mosca. Can be combined with Mosca maintenance contracts - all from one source.

CONTACT US FOR A PERFORMANCE CONSULTATION!

mosca.com

Mosca GmbH
Gerd-Mosca-Straße 1 · 69429 Waldbrunn

info@mosca.com · +49 6274 / 932-0